

ELGR toothed belt axis

FESTO



Cost-optimised and with a longer service life of 5,000 km.

First choice for automation tasks with relatively low requirements for load, dynamic response and precision: the ELGR toothed belt axis – in 3 sizes with strokes of up to 1.5 m, a speed of 3 m/s and a repetition accuracy of $\pm 0.1\text{mm}$.

Cost-optimised: the design

The cost-optimised design opens up a wide spectrum of applications at the best price-performance ratio.

Simple engineering

Identical mounting accessories and the open motor interface also allow mounting of third-party motors. The simple layout of the axis, together with the PositioningDrives software and pre-defined parameter sets in the FCT configuration software, mean that the entire solution can be put into operation in almost no time at all.

Perfectly dimensioned all round

The ELGR is suitable for any conceivable installation situation. The space-saving, easy-to-operate endposition sensing ensures greater safety when the unit is in operation. One longer slide and two additional slides are available for higher loads and better guiding behaviour.

ELGR = ready-to-install for quick construction

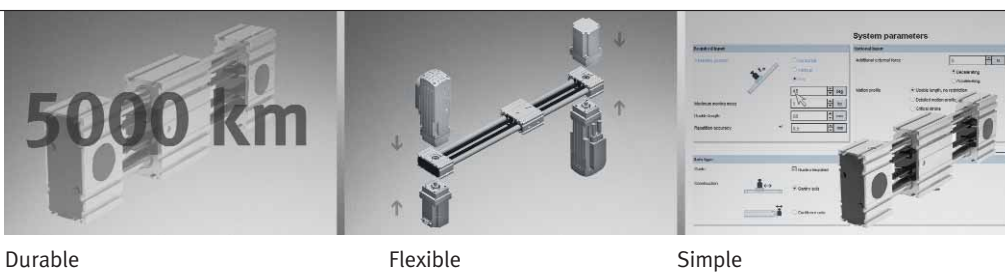

Durable

Flexible

Simple

168.1. PSI →

Product Short Information

ELGR toothed belt axis

Options

- Sliding bushings
- Ball bearings for higher speeds and loads
- Long slide for higher loads
- 1 or 2 additional slides
- Sensor bracket and switch lug for endposition sensing
- Axial kits for Festo servo and stepper motors
- Profile mountings

Typical fields of application

- Pick & Place tasks and transportation of small masses (< 15 kg) with low requirements for repetition accuracy and process forces
- Centring packages on conveyor belts with slides running in opposite directions
- Positioning packages on conveyor belts
- Activating safety doors in processing machines
- Pusher function on conveyor belts

Typical ranges of application

- Semiconductor industry
- Electronics industry
- Light assembly industry
- Metalwork industry
- Mounting small parts
- Optical industry
- Precision mechanics
- Laboratory automation
- Industrial packing machines

ELGR with optional sensor technology

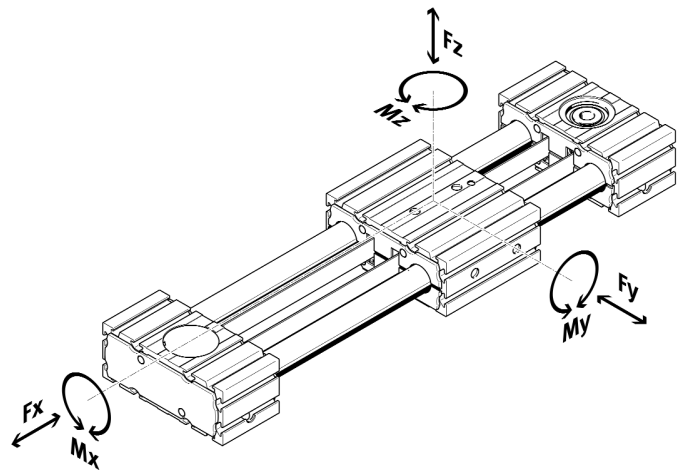

Technical data

Size (= width of the axis profile)	35		45		55	
Guide type	BBG	PBG	BBG	PBG	BBG	PBG
Stroke [mm]	50 to 500		50 to 1000		50 to 1500	
Max. feed force Fmax [N]	50		100		350	
Max. speed [m/s]	3	1	3	1	3	1
Mx [Nm]	2.5	1	5	2,5	10	5
My [Nm]	6	3	12	6	24	12
Mz [Nm]	6	3	12	6	24	12
Accuracy [mm]	±0.1					

BBG = ball bearing guide, PBG = plain-bearing guide

Festo AG & Co. KG

Ruiter Strasse 82
73734 Esslingen
www.festo.com
Tel. +49 711 347-0
Fax +49 711 347-2144
service_international@festo.com